

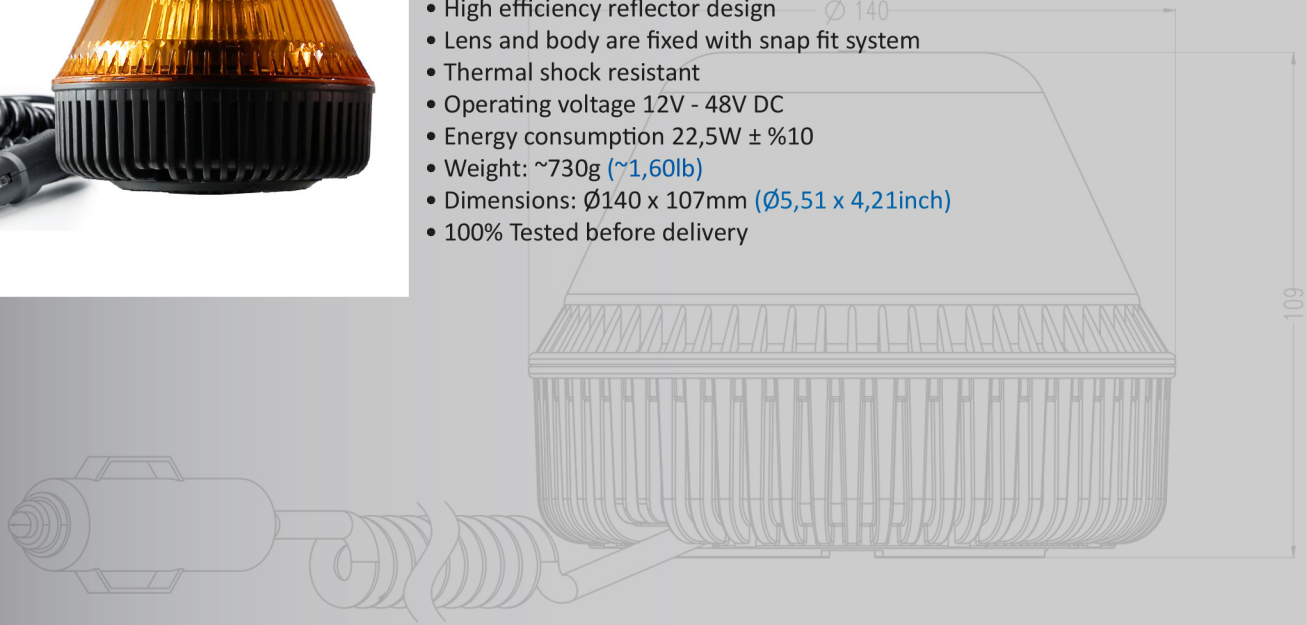



FDL140 LED BEACON LAMP - MAGNET



Features

- Homologated according to ECE R10 and ECE R65
- Compact, esthetic and elegant design
- Power LED Technology
- Thermal conductive polymer body
- High efficiency reflector design
- Lens and body are fixed with snap fit system
- Thermal shock resistant
- Operating voltage 12V - 48V DC
- Energy consumption 22,5W ± %10
- Weight: ~730g (~1,60lb)
- Dimensions: Ø140 x 107mm (Ø5,51 x 4,21inch)
- 100% Tested before delivery



PARTS	PARTS NAME	PARTS NO
	FDL140 LED BEACON LAMP-MAGNET-AMBER Homologated	0001.3014.XXX
	FDL140 LED BEACON LAMP-MAGNET-NATURAL Not Homologated	0001.3014.XXX
	FDL140 LED BEACON LAMP-MAGNET-RED Not Homologated	0001.3014.XXX

LENS	
AMBER	0001.0351.000
NATURAL	0001.0351.001
RED	0001.0351.002

